

2-WAY SLATWALL MERCHANDISER

Items # WDSWH24(-BK, -MP, -WH),
WDCAS2H24

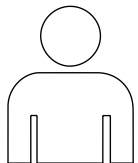
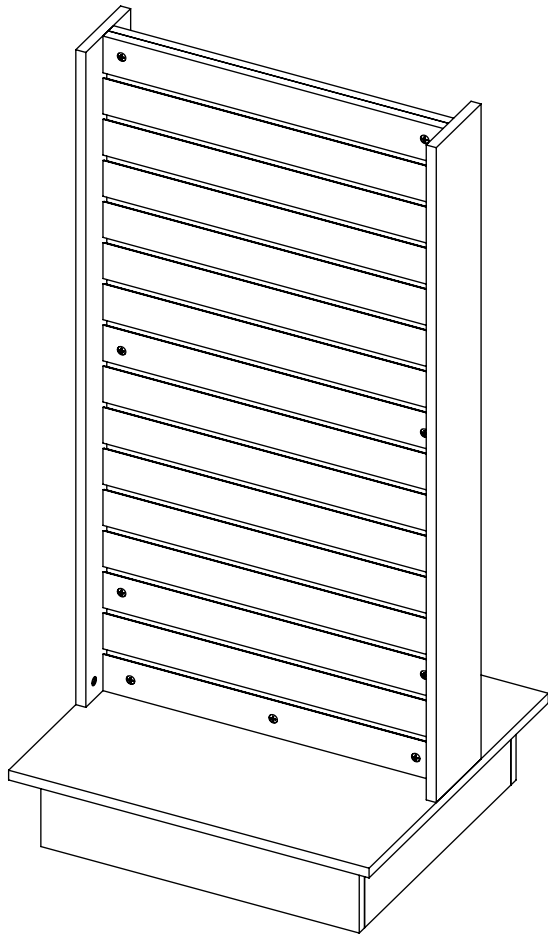

**2-3 PEOPLE
REQUIRED
FOR
ASSEMBLY**

INCLUDED HARDWARE

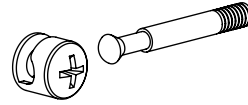

38X
CAM LOCK AND STEM



22X
STICKER

TOOLS REQUIRED

SCREWDRIVER

1

- INSERT STEM ON FRONT BASES.
- ASSEMBLE WITH SIDE BASES.

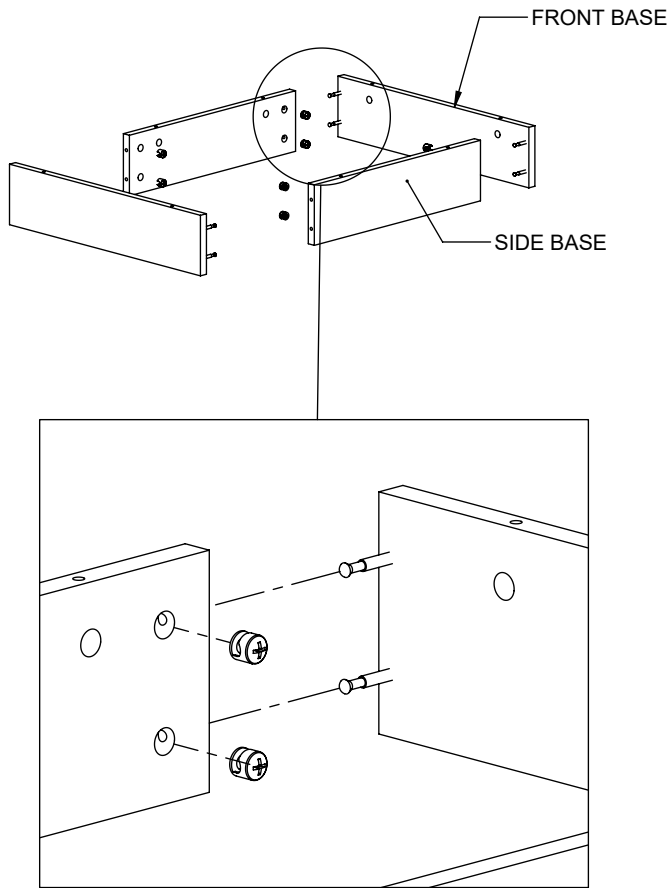
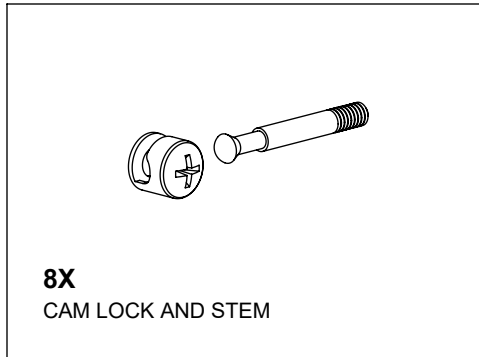

2

- INSERT STEMS ON BOTTOM OF FLOOR PANEL.
- ASSEMBLE AS SHOWN.

IF CASTER KIT WAS NOT PURCHASED, SKIP TO SHEET 5.

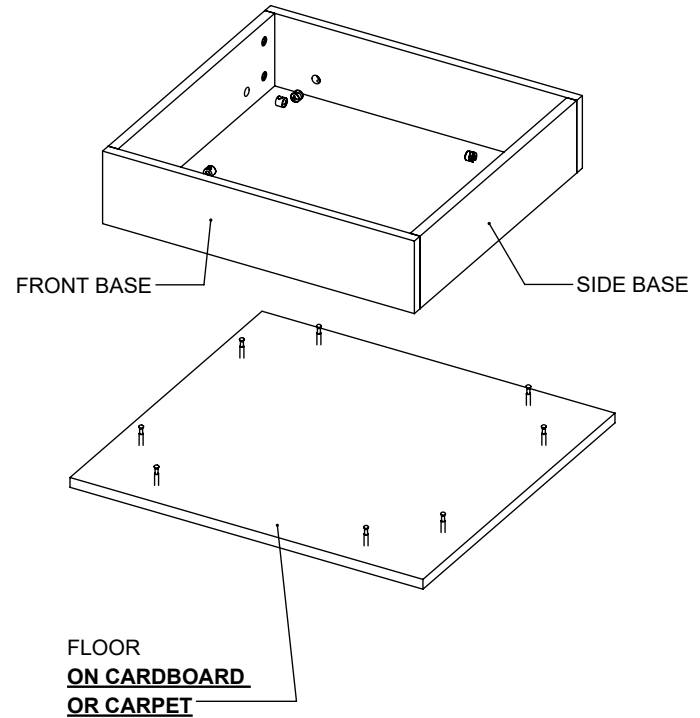
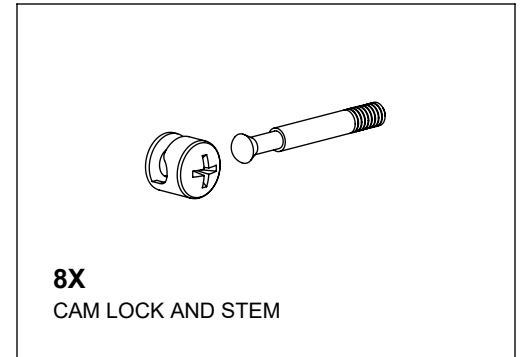

CASTER KIT INSTRUCTIONS

ITEM #WDCAS2H24

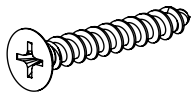
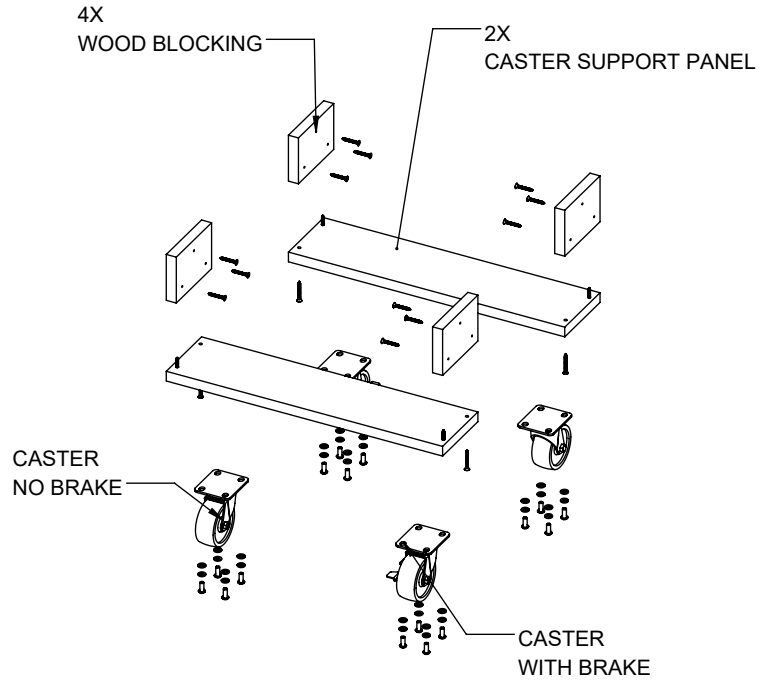

12X
#8 X 1.18" LONG
FLAT HEAD WOOD SCREW

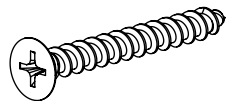

8X
#8 X 1.42" LONG
FLAT HEAD WOOD SCREW

1

PUT WOOD BLOCKING ON
4 CORNERS, AND SCREW
IN WITH WOOD SCREWS.

NOTE THE LONG AND
SHORT SIDES OF THE
BASE.

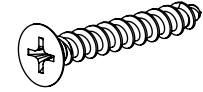

12X
#8 X 1.18" LONG
FLAT HEAD WOOD SCREW

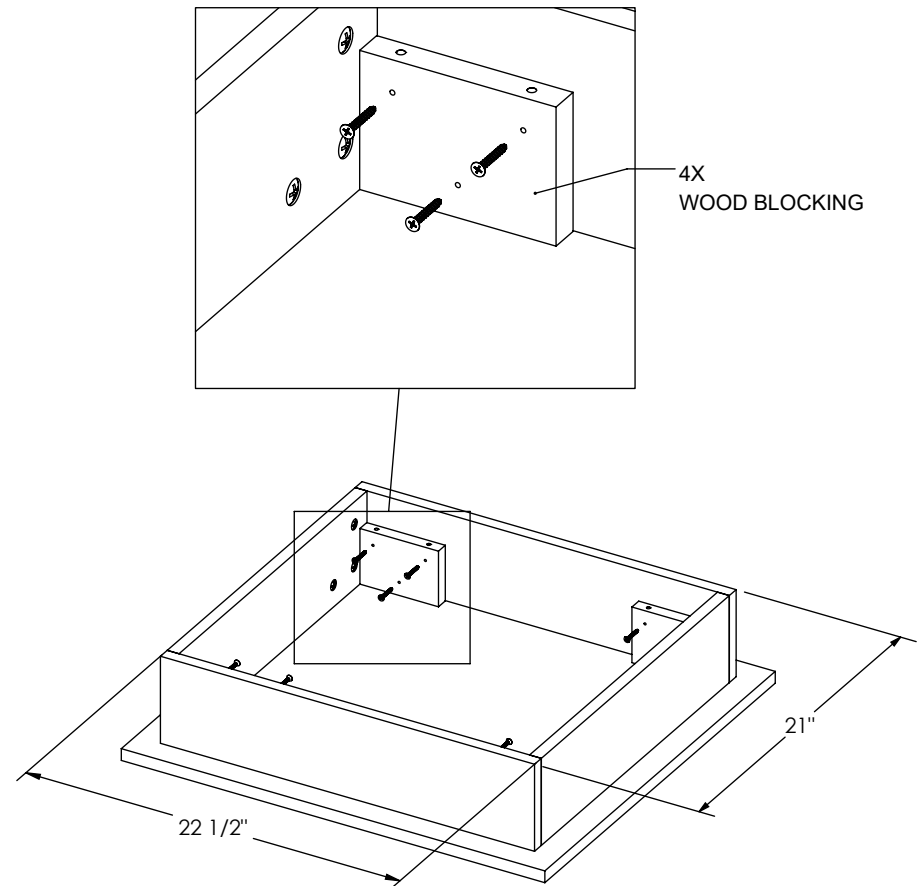

2

PUT CASTER SUPPORT
PANEL OVER WOOD
BLOCKING, AND SCREW IN
WITH WOOD SCREWS.

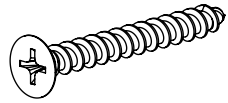

8X
#8 X 1.42" LONG
FLAT HEAD WOOD SCREW

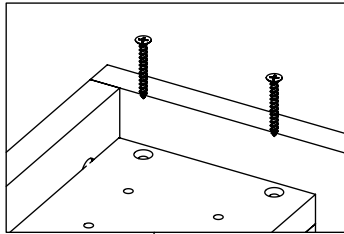

2X
CASTER
SUPPORT
PANEL

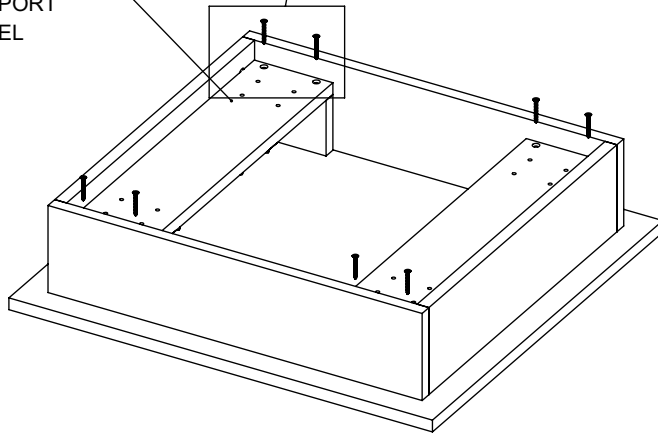

3

PUT CASTERS WITH
BRAKES AND CASTERS
WITHOUT BRAKES ON
OPPOSITE CORNERS.

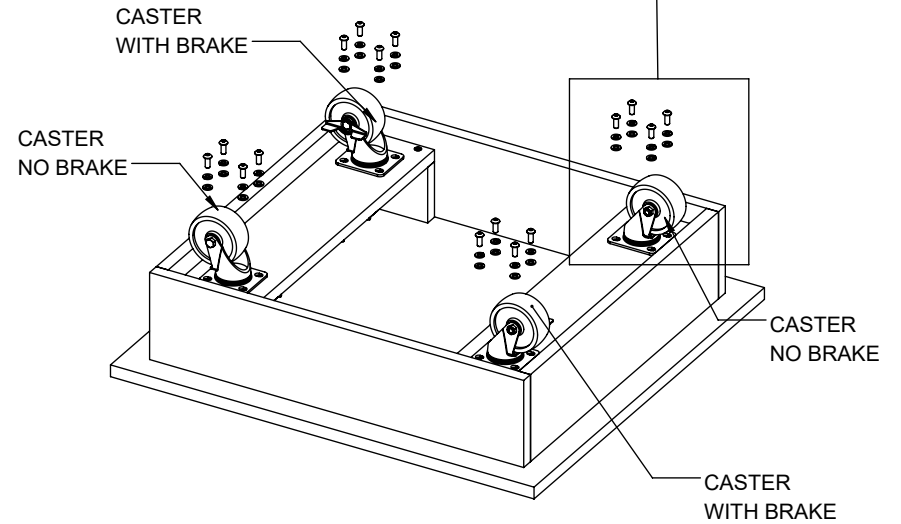
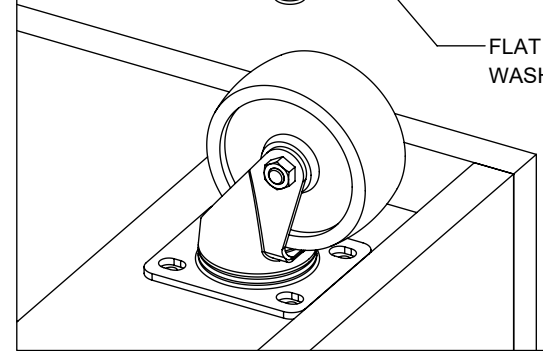
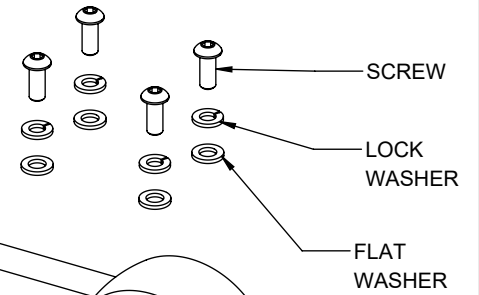

**2-WAY SLATWALL MERCHANDISER
INSTRUCTIONS
(CONTINUED FROM SHEET 2)**

3

- INSERT STEMS ON SIDE PANELS.
- ASSEMBLE AS SHOWN.

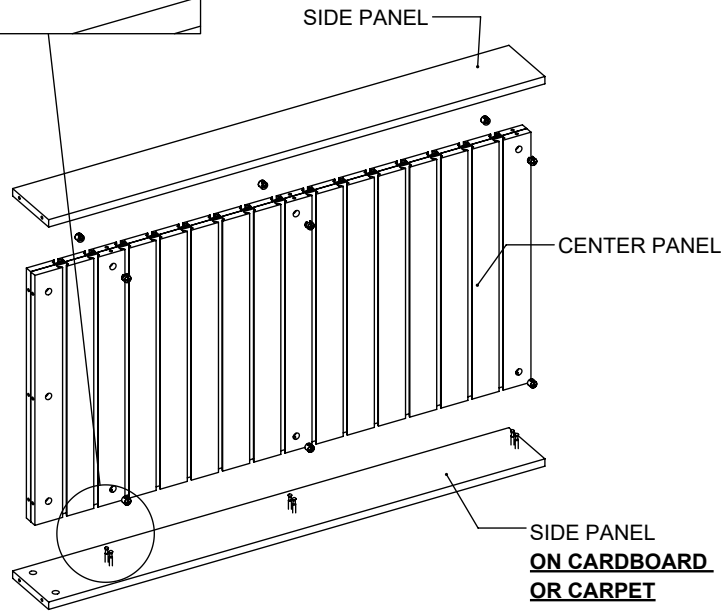
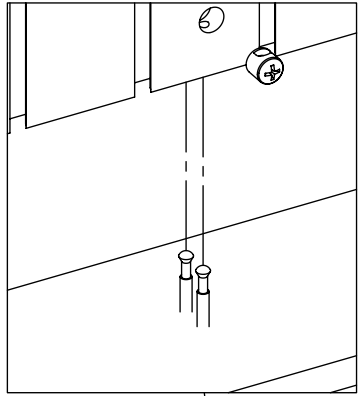

12X
CAM LOCK AND STEM

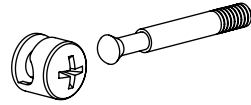

4

- INSERT STEMS ON FLOOR.
- ASSEMBLE AS SHOWN.

10X
CAM LOCK AND STEM

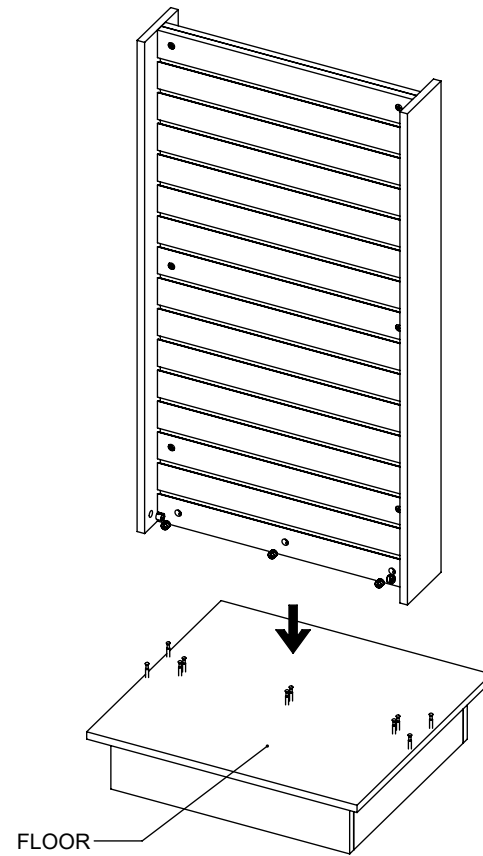
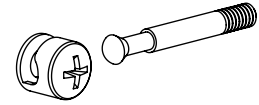

5

- SLOWLY STAND UP THE UNIT.
- PUT STICKERS ON EXPOSED CAM LOCK HOLES.
- ASSEMBLY IS COMPLETE.

